

ADDITIONAL INSTRUCTIONS
FOR THE USA VERSION

1974

Dino 246 GT

**SUPPLEMENT TO THE OPERATING,
MAINTENANCE AND SERVICE HANDBOOK**

Only the main features of this car differing from standard production DINO 246 GT are described in this supplement. Section and paragraph of the standard instruction book to which the alterations are referred to are clearly shown in this supplement. For all remaining parts, please refer to the standard instruction book.

1 – GENERAL SPECIFICATIONS

IDENTIFICATION PARTICULARS.

In addition to the standard identification numbers and plates, the following tags are provided:

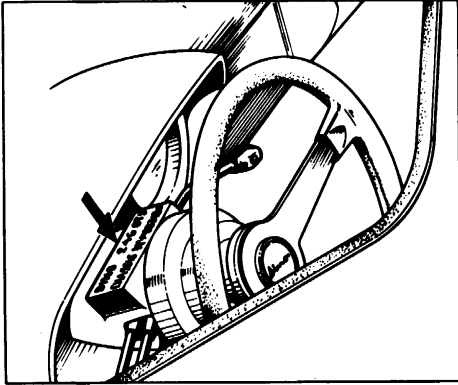

1) – U.S. Safety standard 115 tag:

showing the type of the vehicle and chassis number, is located on the top of the steering pillar cover.

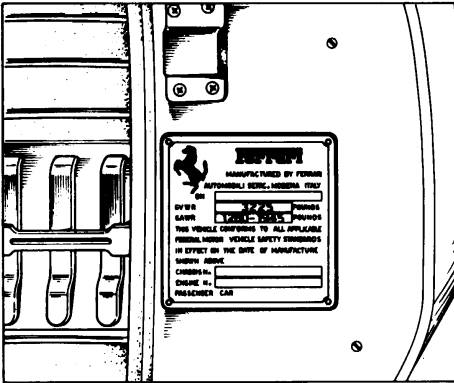

2) – U.S. Safety standard conformity tag:

showing the year and month of manufacture, the Gross Vehicle Weight Rating, the Gross Axle Weight Rating (first number for front axle, second number for rear axle), the chassis number, is applied on left side door pillar, below lock striker.

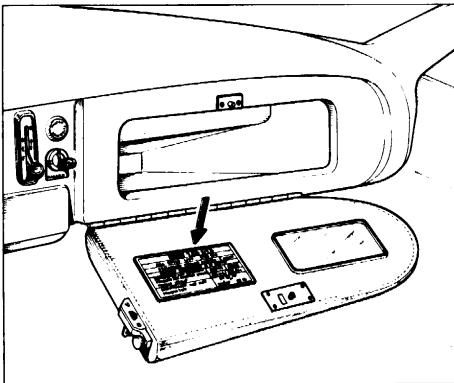

3) – U.S. Safety standard 110 tag:

showing tyre data and vehicle capacity, is located on the back of glove box lid, on the right of vanity mirror.

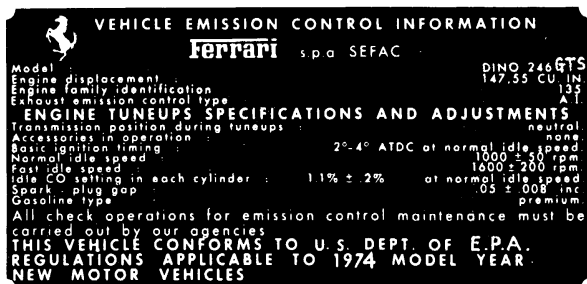

4)-Air pollution tag:

Showing the main data for correct engine adjustment according to which the car meets the regulations on air pollution is located on the back of engine compartment lid, on left hand side.

FERRARI IDLE SETTING PROCEDURE.

1) Green engine

Check the idle CO at the tail pipe:
 the CO must be 1,1%±0,2% at 1000±50 R.P.M.
 If not, it is necessary to reset the idle CO cylinder by cylinder at the following values:
 CO 1,1%±0,2% at 1000±50 RPM.
 (As shown in the air pollution tag).

2) Car with 2500 miles or more :

Check the idle CO at the tail pipe:
 the CO must be below 1,5% at 1000RPM±50.
 If not it is necessary to reset the idle CO cylinder by cylinder at the following values:
 2,5%±1% at 1000 RPM ± 100.

GASOLINE : With octane rating of at least 91 (Research method).

VEHICLE WEIGHTS AND CAPACITIES

Curb weight	2850 lbs
Vehicle load capacity (total 375 lbs)	2 adults(300 lbs)—75 lbs of luggage
Gross weight (fully laden)	3225 lbs
Designated seating capacity	2 persons
Occupant distribution	2 in front

TYRES

Michelin	205 — 70 — VR 14	
	or ER 70 — 14	
Goodyear	205 — 70 — VR 14	
Pressure	Front 28 p.s.i.	Rear 32 p.s.i.

Rubber lugs are provided in tread grooves to serve as visual wear indicators :

when tyre is worn down to their level it should be replaced.
 (U.S. Safety standard 109).

INSTRUMENTS AND CONTROLS

- 1—Electric clock.
- 2—4—Direction indicator and vehicular hazard warning lights: flash separately to show operation of RH or LH direction indicators; flash simultaneously to show operation of vehicular hazard warning signal.
- 3—Main beam warning light.
- 5—Speedometer.
- 6—Low oil pressure warning light (Red)
- 7—Electrically actuated oil pressure gauge.
- 8—Oil thermometer.
- 9—Odometer zero control.
- 10—Water thermometer.
- 11—Reserve fuel warning light (red).
- 12—Fuel level gauge.
- 13—Revolution counter.
- 14—Ammeter.
- 15—Air outlets adjustable as to air direction and flow.
- 16—Left hand side defroster control lever—Position 0 : closed—position ↓ : air to defroster and to feet—position ↑ : air only to defroster.
- 17—Heater valve control - Red spot : warm air Blue spot : fresh air.
- 18—Right hand side defroster control lever -Position 0 : closed—position ↓ : air to defroster and to feet - position ↑ : air only to defroster.
- 19—Button for opening glove compartment.
- 20—Vehicular hazard warning signal switch.
- 21—Space for radio installation.
- 22—Side air inlet.
- 23—Button for adjusting clock.
- 24—Instrument illumination rheostat.
- 25—Radio aerials switch (optional).
- 26—Front compartment opening control.
- 27—Brake pedal.
- 28—Side air inlet.
- 29—Clutch pedal.
- 30—Accelerator pedal.
- 31—Brake system effectiveness indicator: it lights up as soon as the engine is switched on and goes out when the engine starts, to make sure that the bulb is operable.
If it lights up while the car is running, it shows a brake system failure.
- 32—Parking light indicator.
- 33—Parking brake warning light.
- 34—Ignition switch.
- 35—Blower fan switch for warm or fresh air to defroster or to feet.
- 36—Gear lever.
- 37—Cigarette lighter.
- 38—Ash — tray.
- 39—Handbrake lever.
- 40—Choke control lever with "choke" inscription engraved.
- 41—Light switch.
- 42—Main beam/dip beam control lever.
- 43—Direction indicator lever.
- 44—Windscreen wiper and screen-washer control.
- 45—Horn button.
- 46—47—LH&RH Electrically operated window winder (optional): it is operable only with the ignition key in position II.
An emergency handle is provided to operate the window winder if the electric device fails.
- 48—"Fasten seat belts" warning light.
- 49—Switch panel light (lights RH&LH defroster control levers, heater valve control lever, ventilator blower switch and vehicular hazard warning signal switch).
- 50—Generator warning light.
- 51—Temperature control knob.
- 52—Air flow control knob.

5)-INSTRUMENTS AND CONTROLS

WINDSCREEN WIPER

Is operated by lever 44(fig.5)and its speed is adjustable :

position 1 : low speed.

position 2 : high: speed.

18" blades are provided to wipe windscreen according to U.S.Safety Standard 104. Arm and bladesupports are manufactured with non - glare metal.

The operation of the windshield washer is obtained by tripping the lever towards steering wheel.

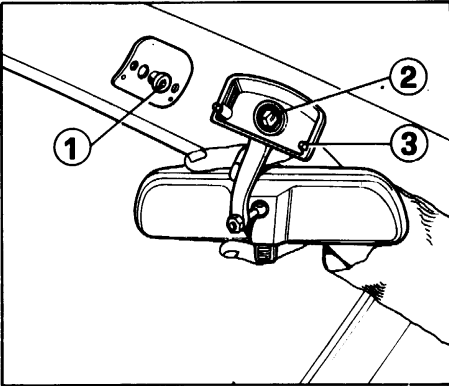

6) —Collapsible inner rear view mirror.

1—Stud; 2—Spring; 3—Location dowels.

COLLAPSIBLE INNER REAR VIEW MIRROR: comes off its seat following an impact; to refit (fig.6), engage spring (2) on stud (1)-make sure the two location dowels (3) are properly registered with relevant seats-by pressing on mirror's base: engagement is of the snap on type. (U.S.Safety Standard 111).

SWIVELING REAR VIEW MIRROR.

on the outside of driver's door, adjustable from driver's seat.

COLLAPSIBLE STEERING WHEEL :

the steering pillar does not move under the effects of a road accident. (U.S. Safety Standard 204).

Steering wheel spokes, spaces and pillar cover are manufactured with non-glare metal. (U.S.Safety Standard 107).

REMOVE KEY INDICATOR :

acoustic signal on when driver's door is opened to leave the car and the ignition key has been forgotten in lock switch.

DEFROSTER

Defrosting of windscreen can be obtained when performing the following operations :

- a) Push levers DEF 16 and 18 into position ↑ (fig.5).
- b) Push lever 17 into position marked with red spot (fig.5).
- c) Switch on blower fans by means of switch 35 (fig.5).
- d) Adjust direction and air flow to windscreen through opening and suitable rotation of air outlets 15 (fig.5).

2 - RUNNING INSTRUCTIONS.

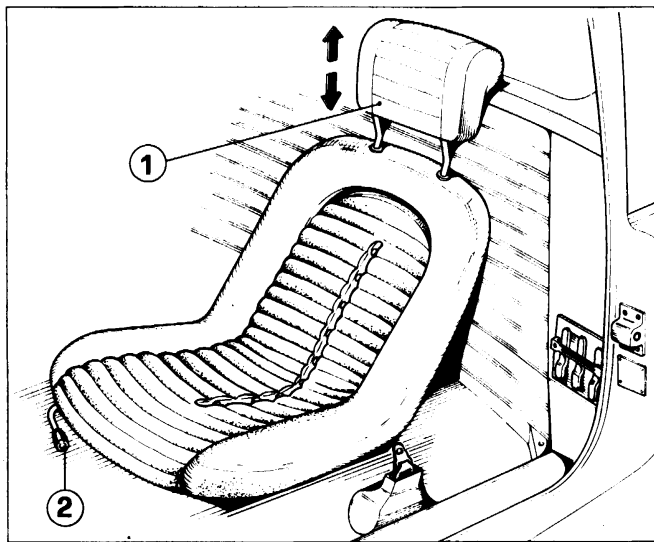

7) - Seat.

- 1 - Adjustable headrest;
- 2 - Slide control lever.

SEATS

Seats squabs with adjustable headrest. (U.S.Safety Standard 202).

Seats can be adjusted on floor after moving control lever(2) downwards. Once the position is set, release the lever and make sure the seat is locked. (U.S.Safety Standard 207).

SAFETY BELTS

Safety belts with retractor are provided as standard original equipment of the 2 point type (lap).

Fasten belts (fig.8)

Pull belt from retractor without stopping; if pulling motion is interrupted, during extension of belt, it will be necessary to return the

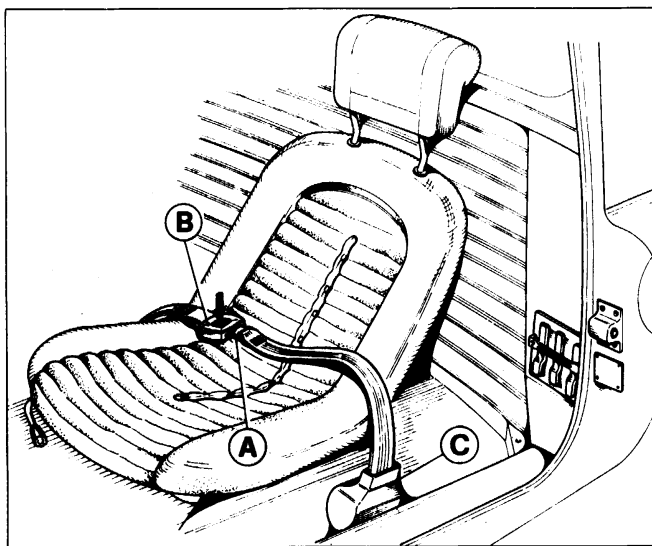

8) - Safety belts.

- A - Lap belt connector.
- B - Buckle.
- C - Retractor.

belt to the stowed position to release the stop mechanism.

To fasten, make sure webbings are not twisted, and then insert connector A into buckle B, slot until a snap is heard. Adjust belt snugly around the hips, not the waist, by allowing excess length to return into retractor.

Warning light and buzzer will go out of action only when, after extending the belts, the retractors begin recovery of excess length.

NOTE :

Warning light "Fasten seat belts" (fig. 5N.48) and buzzer will not be in action while safety belts are not fastened only in the following cases :

- 1—Ignition key in position 0 (off.).
- 2—Engine running and gears in neutral.

Warning—The adjustment of seat belts must be made before starting the car and after having properly positioned the headrests and rear view mirrors.

To release yourself from the belt restraint simply press in the center button to release the buckle.

Each belt is intended for use by one adult or one child over 6 years of age.

Belt adjustments must be made with occupant sitting well back and erected in the seat.

Occasionally, check that mounting bolts are tight, and that webbing is not cut or frayed.

In the event of an accident, even if the belt you were wearing is apparently undamaged it is recommended that you replace it with a new belt.

To keep belts clean, hand wash only, using warm water and mild soap. Rinse and dry thoroughly—out of direct sunlight.

Do not use strong detergents.

Do not use bleaches or dyes.

Avoid any chemical that may weaken the equipment.

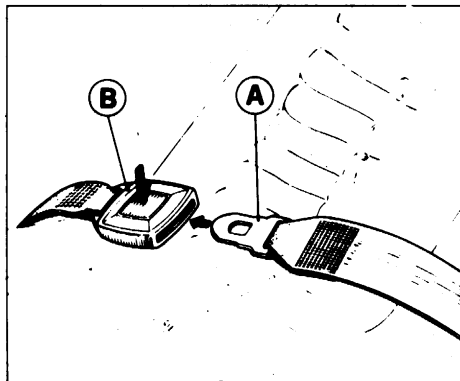

9)—Fastening and releasing safety belts.

A — Lap belt connector.

B — Buckle.

To clean the retractor blow with dry and clean compressed air into the retractor housing.

Users are warned to consult the manufacturers in case of doubt and not to make any alterations or additions to seat belt assemblies and/or anchorages.

IGNITION AND STEERING LOCK.

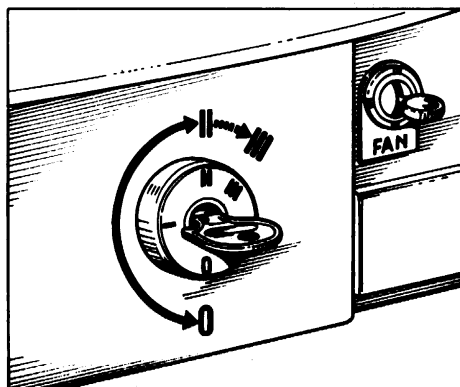

10)—Ignition and steering lock.

The lock switch (fig. 10) has no position I (garage); consequently, the key can be inserted or withdrawn exclusively when the switch is in position 0 according to U.S. Safety Standard 114.

STARTING THE ENGINE.

Warning: Normally, engine starting is possible only when the driver and/or passenger are properly seated and have worn and fastened the seat belt(s) (interlock system)- (U.S.Safety Standard 208)

Unfastening of a belt while car is in motion will put into action the warning light and buzzer, but will not interfere with engine operation.

After a stop-off, the engine may be re-started even if belts are not buckled again, provided the driver remains seated.

Exceptionally, the engine may be started under the following conditions :

1—Seats occupied and belts unfastened (emergency, etc.), or system malfunction :

—In order to start the engine step off the car, press the by-pass switch button inside the engine compartment while the ignition key is in position 0 (off), then carry on

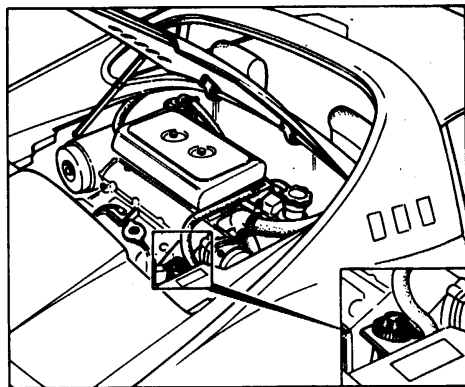

11)-By-pass switch for emergency engine starting.

the usual starting maneuver. Should the first attempt fail, the whole sequence will have to be repeated.

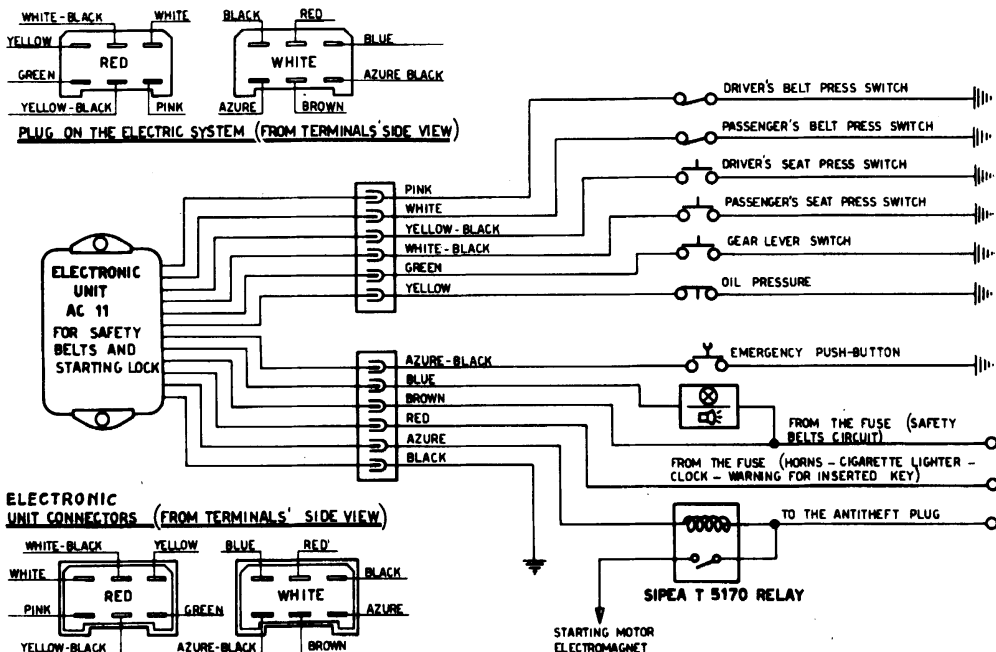

12)-Interlock system wiring layout.

2—Seats unoccupied (example : engine operational checks, tune ups, etc.) :

—In order to start the engine, operate the lock switch standing outside the car.

—In the above cases of unfastened belts, the warning light and buzzer will go into action when car is put into forward gear. Once you are properly seated a memory of the interlock system allows you to raise temporarily (no longer than 10 sec.) from the seat with belt buckled without interrupting the sequence.

Should you unfasten belts, while doing this, the memory of the system will be canceled and, in order to start engine you will have to sit down and buckle seat belts again. To prevent possible occasional starting difficulties, or intermittent operation of the light and buzzer reminder system while driving, do not put packages or briefcases on the passenger seat.

STARTING PROCEDURES.

COLD ENGINE

Two Starting Procedures :

- 1)When the car has been parked at ambient temperature above 60° F.
- 2)When the car has been parked at ambient temperature below 60° F.

-
- 1)Procedure (above 60° F.).
 - a)Make sure the gear lever is in neutral position.
 - b)Turn the ignition key to the position "II"
 - c)Wait for 30 seconds until the electric fuel pumps have slowed down.
 - d)Depress the clutch pedal.
 - e)Press the throttle pedal fully open one time.
 - f)Turn the key until it goes over position "II" and at the same time give one or two partial accelerations for starting the engine.

g)As soon as the engine fires, maintain the idle speed at 2500 — 3000 RPM during the first 20 seconds.

h)If the engine doesn't start or stalls, it is necessary to turn the ignition key back to position 0, then turn it over position "II" and follow as at point f.

2)Procedure (below 60° F.).

- a)Make sure the gear lever is in neutral position.
- b)Pull the choke lever all the way back.
- c)Turn the ignition key to the position "II".
- d)Wait for 30 seconds until the electric fuel pumps have slowed down.
- e)Press the clutch pedal and turn the key until it goes over position "II" for starting the engine.
- f)As soon as the engine fires push the choke all way forward.

HOT ENGINE.

When the engine is warm the choke lever used for cold start, should not be touched. When the engine is very hot it is helpful to open fully the throttle when attempting to start, closing gradually as soon as the engine fires.

Do not pump the throttle pedal as this will make the engine excessively rich due to the action of the mechanically operated accelerator pumps, thus making hot starting more difficult.

If the oil temperature is below 140° F the engine will run at 1200 rpm, being connected to an automatic fast idle device controlled by the oil temperature.

Arising the oil temperature the idle engine revs can reach about 1600 rpm; then, when the oil temperature reaches or exceeds 190° F, the idle speed will be 900 — 1000 rpm.

Warning: if the engine does not start do not pump on the accelerator pedal, as this will wet the sparking plugs, but investigate on the following points :

1—The cranking speed is too slow (battery not properly charged, oil too thick or too cold).

- 2—Ignition equipment faulty (sparking plugs damp,contact points dirty or wrongly adjusted, coils or condensers inoperative).
- 3—Electric circuits not properly insulated.

4—Ignition fuse burnt out.

Drive the car without hard accelerations until the oil temperature has reached 140°F.

N.B.

For lower temperatures keep the choke on longer.

GEAR LEVER POSITIONS.

The gearshift lever knob has a gating pattern engraved.

(U.S. Safety Standard 102).

When reverse is engaged, with lock switch in position II, the back up light is turned on.

(U.S. Safety Standard 107).

13)-Gear lever positions.

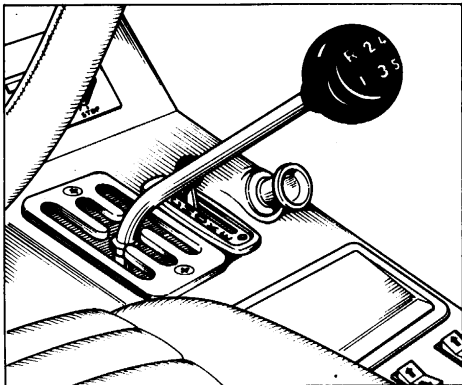

4 - ROUTINE ENGINE MAINTENANCE.

W A R N I N G	PERIODICAL MAINTENANCE OF EXHAUST, CRANKCASE AND EVAPORATIVE EMISSION CONTROL SYSTEMS		W A R N I N G
	periodical mileage	246 DINO GT	
	3'000	check generator belt tension check sparking plugs	
	6'000	replace plugs check high tension wires and plug caps check air pump connections, pipes and valves	
	10'000	check CO% at normal idle speed in each cylinder and check rpm check fast idle revs and fast idle cam setting check distributor microswitch operation check Dinoplex unit, low tension wire and distributor circuit check blow-by pipes and air filter valve check air pump clutch working check pipings and fittings of evaporative control device	
20'000	clean exhaust valves air injectors check distributor advance		

14)-Routine engine maintenance tag.

PERIODICAL MAINTENANCE OPERATIONS.

In addition to the normal prescriptions, it is recommended that the owner of a car e-

quipped with the emission control system follows the emission service schedule printed on the air cleaner cover and listed above.

ALL CHECKINGS AND MAINTENANCE OPERATIONS FOR THE EMISSION CONTROL SYSTEMS SHOULD BE CARRIED OUT BY FERRARI APPOINTED DEALERS.

The Owner is also entitled to free checks of the emission control systems during any free service coupon.

This is in addition to the normal maintenance under warranty which includes tappet clearance, spark timing and distributor dwell angle adjustments.

FUEL SYSTEM

The fuel system is equipped with :

- One electric pump CORONA
- Three dual barrel Weber 40 DCNF 19 carburettors.
- Fast idle device.
- Fuel evaporative emission control system.

SETTING OF CARBURETTORS AND PERIODICAL CHECK OF THE MIXTURE SHOULD BE CARRIED OUT BY FERRARI APPOINTED DEALERS.

For no reason will the Client enrich the mixture and move the screws.

CARBURETTORS

Type Weber 40 DCNF 19	
Choke	mm 32
Central diffusor	mm 4,5
Main jet	mm 1,25
Air correction jet	mm 2,20
Slow running jet	mm 0,55
Slow running air correction jet	mm 1,20
Pump cam	N 11
Pump jet	mm 0,50
Pump valve	mm 1,00
Spring loaded	mm 1,75
Emulsion tube	F / 24
Level float vertical	mm $52 \pm 0,25$
Starter jet	F 6 / 60
Progression holes	1 of mm0,80
	2 of mm0,90
	1 of mm1,30

CARBURETTOR SETTING.

If the engine runs irregularly or stalls, it is necessary to set the slow running; this should be done with the engine warm after having made certain that the ignition equipment and sparking plugs are in good condition.

Proceed as follows :

- 1) Remove the air filter and detach the control 7 (fig.16) of the throttle butterfly relay lever.
- 2) Close completely all the screws 4 (fig15) and unscrew each by two turns.
- 3) Unscrew by one turn the slow running adjustment screw 3 of carburettors 1 and 2. Carburettor N. 1 is regarded as the nearest to the water thermostat.
- 4) With the engine running, open the slow running adjustment screw 3 of carburettor N.3 until the engine is running at 1000 R.P.M..

The use of an electronic rev counter connected to the ignition system and earthed to the engine is recommended for a correct tune up of the engine.

- 5) With the motor-meter synchronising gauge fitted to the intake on the control side of carburettor N.3, adjust the air aperture until the little float is half-way up the sight tube.
- 6) Apply the synchroniser to the intakes of the control side of the remaining carburettors, and check that the float oscillates in the same position. Any variation should not be either above the upper line or below the lower line.
- 7) If the float is not within these limits, slacken the nuts 6 (fig.16) which will move the butterfly control lever until the float is in the correct position. Should the engine speed change, it is necessary to return to the original setting by manipulating screw 3 of carburettor 3. Tighten the nuts controlling the position of the butterfly control lever making sure that this does not produce a tightening of the control.

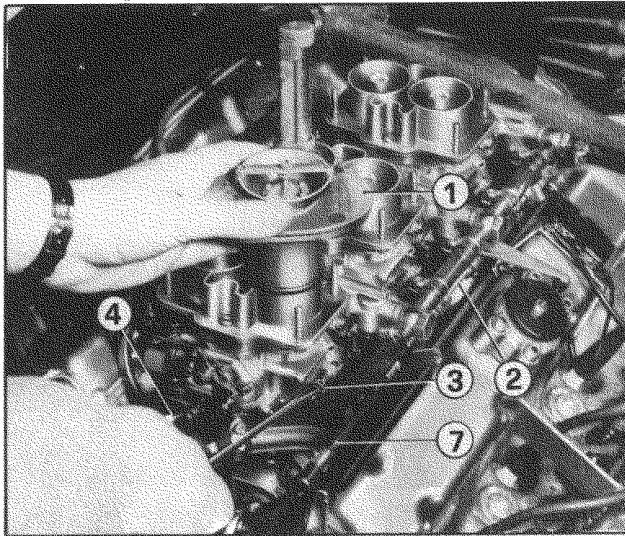

15) Adjusting throttles :

1—Synchronising gauge (moh-tormeter); 2—Butterfly control rod; 3—Slow running adjust-ment screws; 4—Slow running mixture adjustment screws.

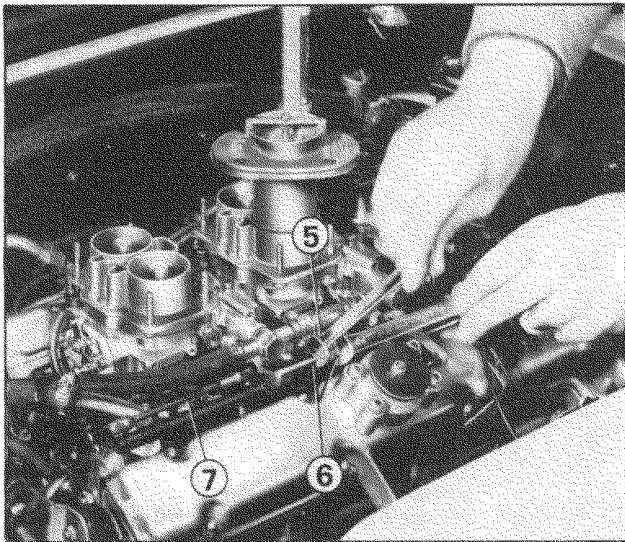

16) Adjustment of butterfly opening: carburetors 1 and 2.

5—Butterfly control rod attach-ment block;
6—Lock nuts;
7—Butterfly relay lever

8) Reduce the engine speed to 1000 R.P.M. adjusting screw N.3 (of carburettor N.3) and carefully adjust the slow running screw 3 of carburetors 1 and 2 until they are just touching their relative abut-ments.

9) In order to obtain the correct mixture setting it is necessary the use of a CO tester (This instrument gives the CO% in

exhaust emission).

Connect the analyzer probe with the pi-pes for CO control fastened on the ex-haust manifolds.

With the engine running 1000 R.P.M., oil and water 194° F adjust the CO% at 1,1 % \pm 0,2 % operating on the mixture screw N.4 fig.15.

Repeat this operation for all the six cylinders.

For cars with 2500 miles or more check the idle CO at the tail pipe: CO must be below 1,5 % at 1000 R.P.M. \pm 100 if not, it, is necessary to reset the idle CO cylinder by cylinder at the following values 2,5 % \pm 1 % then check again the CO% at the tail pipe: it should be below 1,5%.

FAST IDLE DEVICE.

It consists in a cam connected by an arm to the throttle control rod.

The cam rotation is controlled by a bimetallic spring sensitive to the engine oil temperature.

Starting from cold the tappet setting corresponds to the max. lift of the cam and the engine idles at 1200 R.P.M..

While the engine warms up, the idle speed increases gradually to about 1600 R.P.M., then it slows down again to 1000 R.P.M.

FUEL EVAPORATIVE EMISSION CONTROL SYSTEM

To prevent that fuel vapors from tank reach the atmosphere, they are conveyed to an active-carbon trap arranged in the engine compartment where they are absorbed through a proper pipe system.

When the engine is running a hot air stream regenerates the active carbon from which the vapors are extracted and conveyed to the intake manifold.

The system consists essentially of the following parts (fig.18).

- sealed filler cap.
- limited filled tank.
- tank outlet pipes and vapor liquid separator.
- three - way valve performing the following tasks :

a) Slight tank pressurization; air inlet into tank to prevent any possible vacuum;

In this last condition, the tappet is disconnected from the cam.

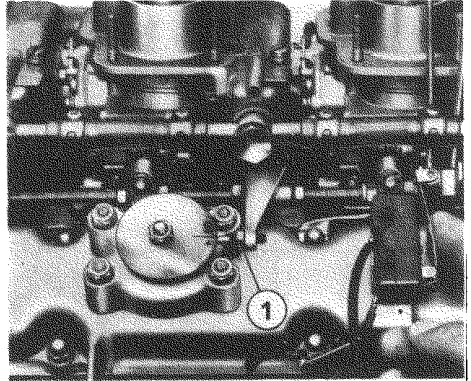

17) Fast idle device.

1—Nut for adjusting tappet.

ADJUSTMENTS OF THE FAST IDLE DEVICE SHOULD BE CARRIED OUT BY FERRARI APPOINTED DEALERS.

b) Safety exhaust to prevent undue overpressure in tank.

—Activated carbon trap.

MAINTENANCE.

A periodic visual inspection of pipings and fittings is recommended.

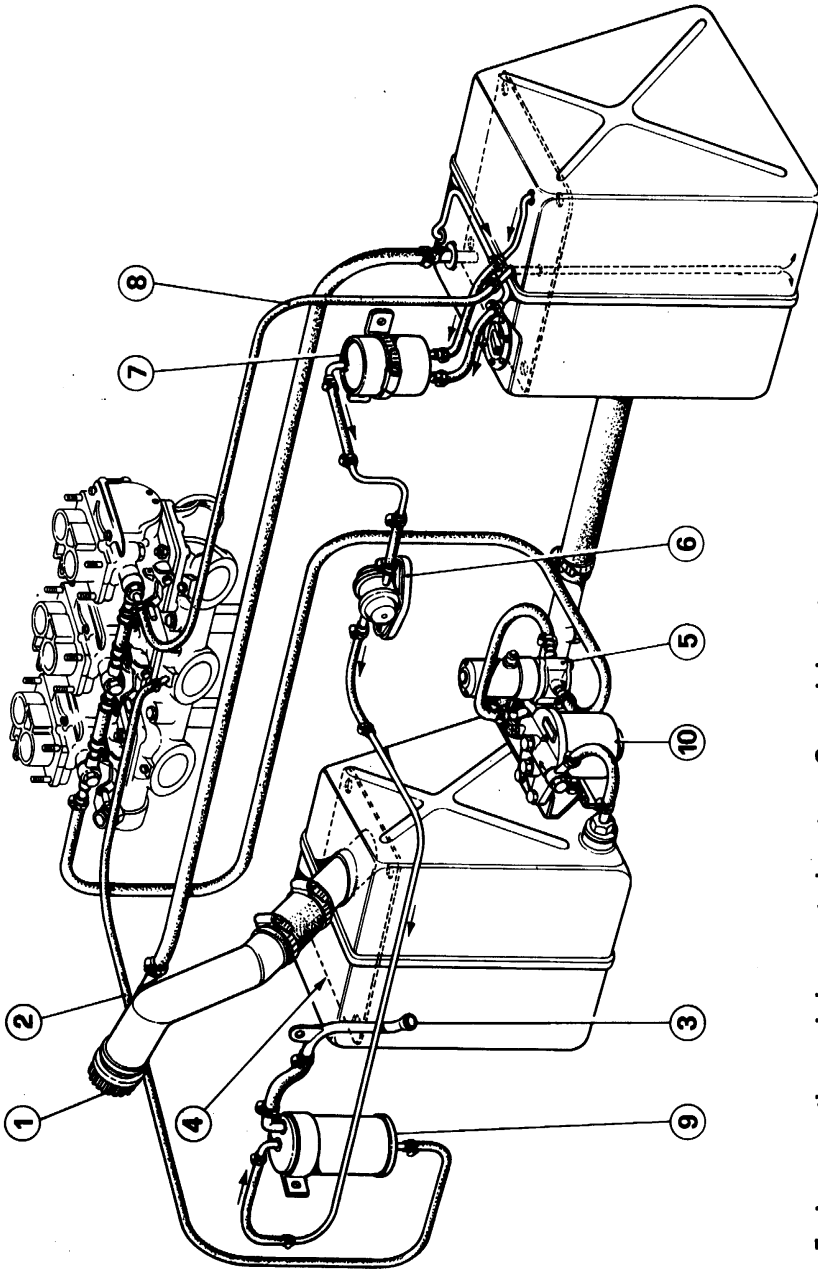

18) — Fuel evaporative emission control system - General layout.

1-Sealed cap; 2-Depression intake on carburetor manifold under butterfly; 3-Hot air purge inlet from left exhaust manifold; 4-Maximum fuel level; 5-Fuel feed pumps; 6-Three-way control valve; 7-Liquid vapor separator; 8-Fuel return pipe from carburetors; 9-Activated carbon trap; 10-Fuel filter.

AIR INTAKE.

In the air intake between the carburettors and the air cleaner there is a valve, the opening of which is controlled by oil pressure. Oil leakage in the circuit of this valve may be the cause of a pressure drop.

In this case stop immediately, check oil level in the sump and have the possible oil leakage repaired by a FERRARI SERVICE.

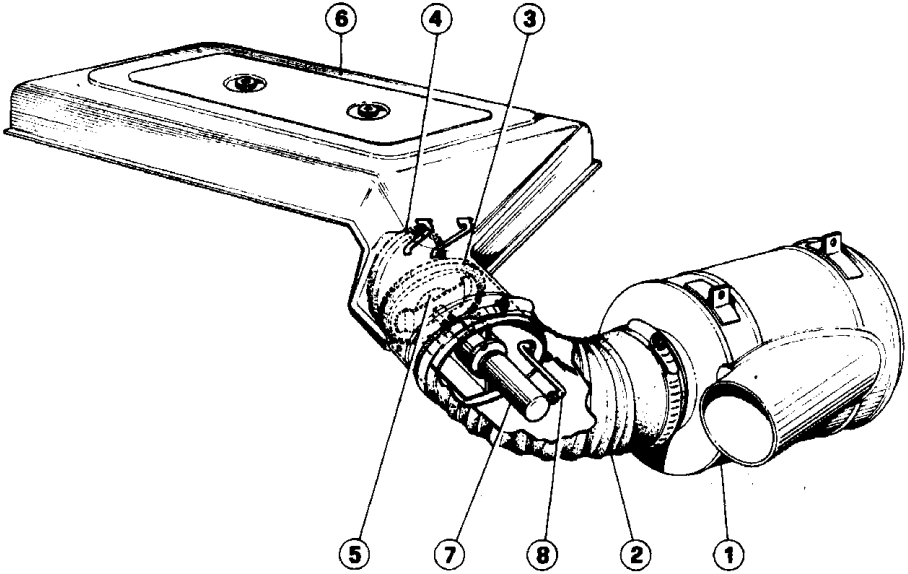
**19) Air intake and valves.**

1—Air filter barrel; 2—Duct; 3—Outer valve (close position); 4—Outer valve (open position); 5—Inner valve; 6—Carburettor upper box; 7—Valve control piston; 8—Oil pipe.

AIR INJECTION SYSTEM.

It is provided to keep the exhaust contamination to a minimum, burning the unburnt portion of the exhaust gases.

It consists of :

- Air pump with electromagnetic clutch which disconnects the pump when the engine speed reaches 4200 RPM (fig.20).
- Air injectors (one for each cylinder) fitted on the exhaust manifolds (fig.21).
- Air diverter valve.
- Check valves (two).
- Air manifolds (two).
- Tubes and hoses connecting the various components.

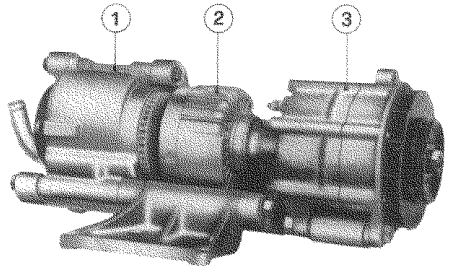
**20) Air pump fitted on car.**

- 1—Air pump;
- 2—Electromagnetic clutch;
- 3—Alternator.

CHECKS AND MAINTENANCE SERVICES OF THE AIR INJECTION SYSTEM SHOULD BE CARRIED OUT BY FERRARI APPOINTED DEALERS.

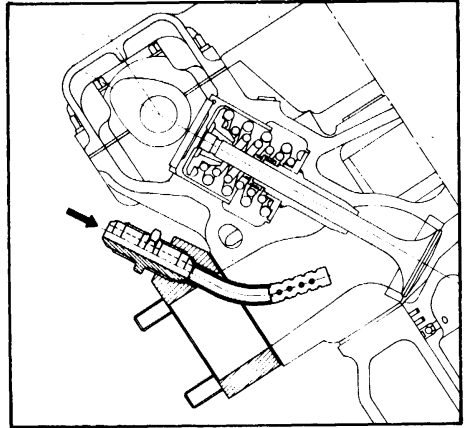

21) –Air injector on exhaust manifold port.

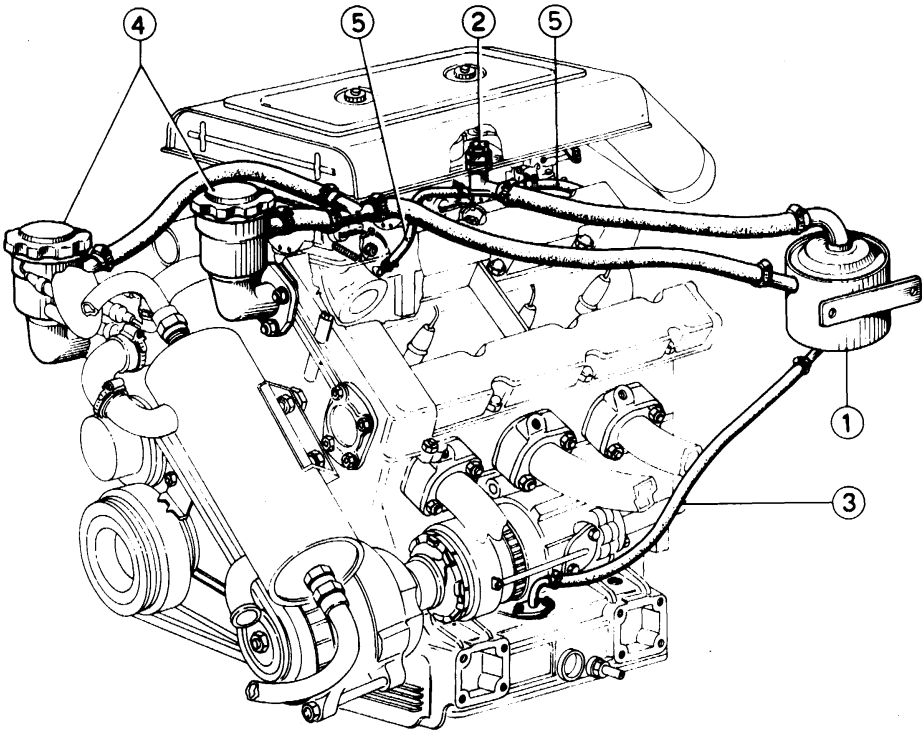

22) –Blow – by recirculation system layout.

1-Oil vapour condenser; 2-Crankcase pressure limiting valve; 3-Oil drain tube from condenser to sump ; 4-Oil filler caps; 5-Calibrated intakes to induction manifold.

IGNITION.

The ignition system is fed from a 12 volt 60 ampere hour battery. There is a Marelli distributor type 50.10.256.3 or S 125 C, (50.10.256.3 is the experimental type number, S 125 C is the production type number), with double breaker points, one R1 normal, and one R2 retarded of $5,5 \pm 1$ of coil ignition in comparison with R1 (fig.23). Contact breaker gap mm. 0,32 to 0,38 (0,012" to 0,015").

- Basic ignition advance: $2^\circ \pm 2^\circ$ ATDC (engine degrees).
- With R1 breaker point: $9^\circ \pm 2^\circ$ BTDC (engine degrees).
- Total advance $39^\circ \pm 2^\circ$ BTDC over 5500 R.P.M.
- Firing order 1 - 4 - 2 - 5 - 3 - 6 .
- Coil Marelli BAE 203 A.
- Dinoplex C electronic unit AEC 103 A Marelli.
- Sparking plugs: Champion UN 19V.

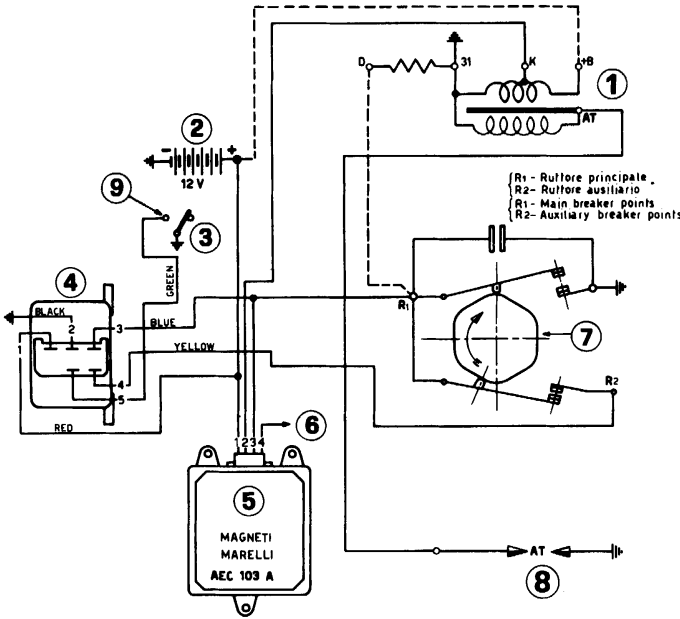

23) Dinoplex unit connections.

1—Coil Marelli BAE 203 A; 2—Battery; 3—Microswitch; 4—Anti-hop device for microswitch N.SSM 1B—64814011; 5—Electronic ignition; 6—Electronic rev counter; 7—Distributor Marelli; 8—Plugs; 9— Normally closed point of the microswitch.

————— Normal ignition wiring layout.

----- Emergency ignition wiring layout.

RUNNING AT NORMAL REVS : R1

○ ◁ OPENING ANGLE $28^\circ \pm 2^\circ$ CLOSING ANGLE $32^\circ \pm 2^\circ$

Running at low revs (R1 connected to R2): angles altered of $5^\circ 30'$ distributor (Retard angle of R2 in respect to R1).

● ◁ Opening angle $22^\circ 30' \pm 2^\circ$; closing angle $37^\circ 30' \pm 2^\circ$.

1 - MICROSWITCH CONTROLLED BY CARBURETTOR SHAFT LEVER.

R1- MAIN CONTACT BREAKER.

R2- AUXILIARY CONTACT BREAKER.

○ DWELL - 53,5 %

● DWELL - 62,5 %

DISTRIBUTOR MARELLI S125C (50.10.256.3).

ADVANCE DEGREES ON THE DISTRIBUTOR
GRADI ANTICIPO SU DISTRIBUTORE

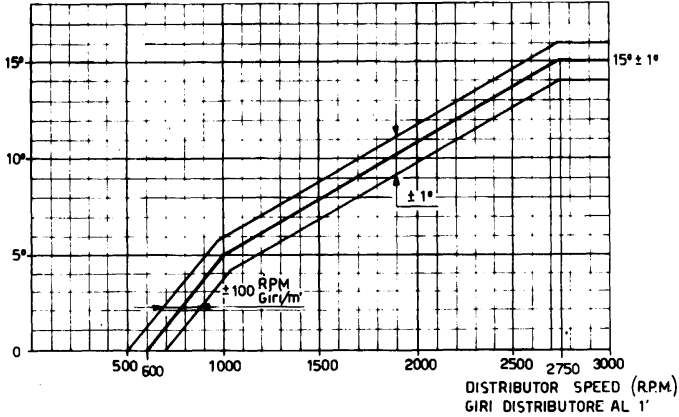

24) Automatic advance variation.

ENGINE ADVANCE DEGREES
GRADI ANTICIPO SUL MOTORE

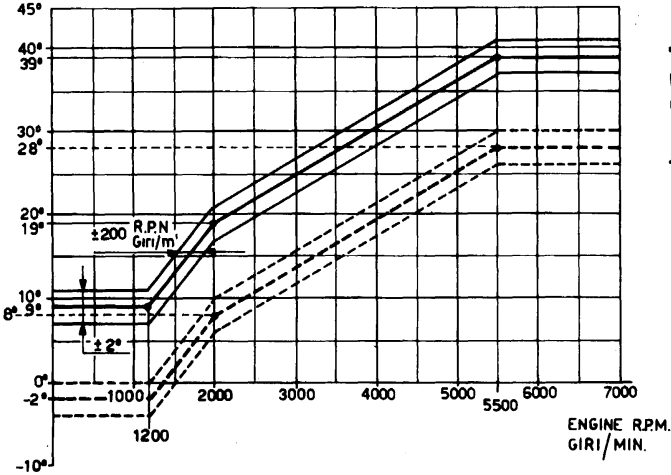

25) Ignition advance diagram.

———— Ignition advance full power carried out with normal points.

- - - - Ignition advance during the cycle carried out with retarded points.

DINOPLEX ELECTRONIC UNIT.

The engine normally operates via the electronic ignition system.

Only in the event of irregular running of the Dinoplex unit, the electronic ignition system can be excluded.

To this purpose, move the snap-in plug(1) into the seat (2).

The terminals must only be moved to the "Emergency" position with the ignition key switched off.

Under these conditions ignition is via battery, distributor and ignition coil.

When the emergency ignition is switched on the revolution counter is not working.

WARNING

High voltage ignition.

It is dangerous to touch the high voltage cable terminals whilst the engine is running.

All work on the equipment should only be carried out with the ignition key removed.

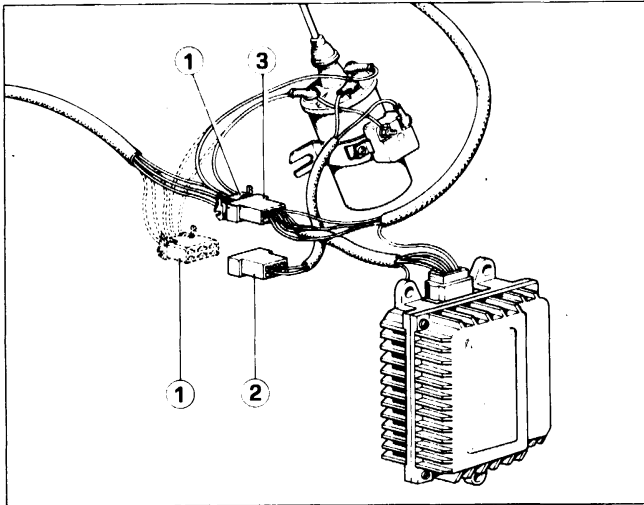

26)–Layout of the normal and emergency ignition

1–2–Plug to connect emergency ignition; 1–3–Plug to connect electronic ignition.

6 - ELECTRICAL INSTALLATION.

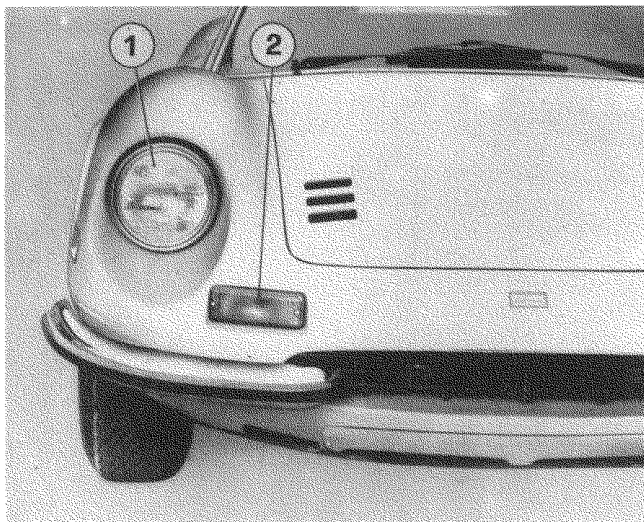
**27) - Front lights.**

1—Sealed beam (main beam and dip beam headlights with white bulbs 55W).

2—Side and direction indicator lights (twin filament bulb 5/21W).

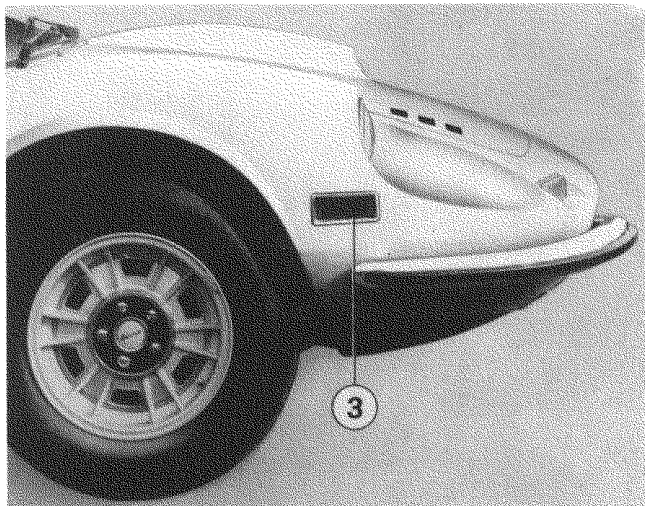
**28) - Front side marker.**

3—Front side marker light (bayonet coupled bulb 2W).

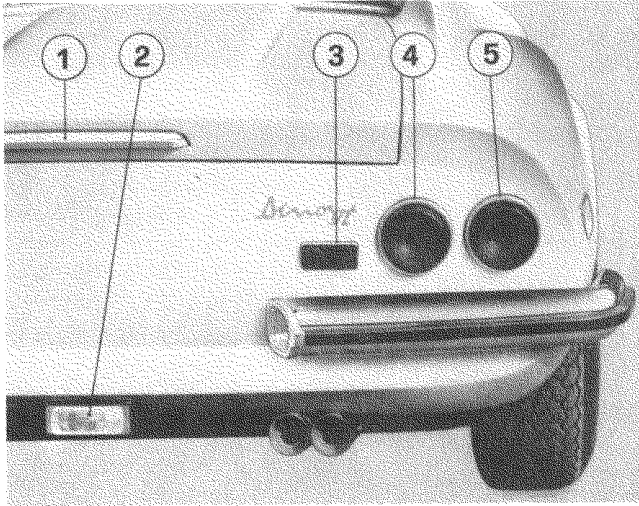

29) – Rear lights.

- 1—Number plate lights (two 5W bulbs).
- 2—Back-up light (21W bulb).
- 3—Reflex reflector.
- 4—Stop and parking light (twin filament bulb 5/21W).
- 5—Direction indicator light (21W bulb).

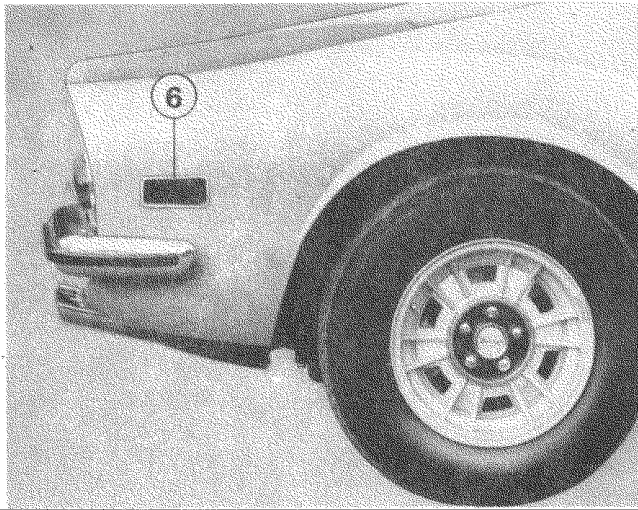

30) – Rear side marker.

- 6—Rear side marker light (bay - onet-coupled bulb 2W).

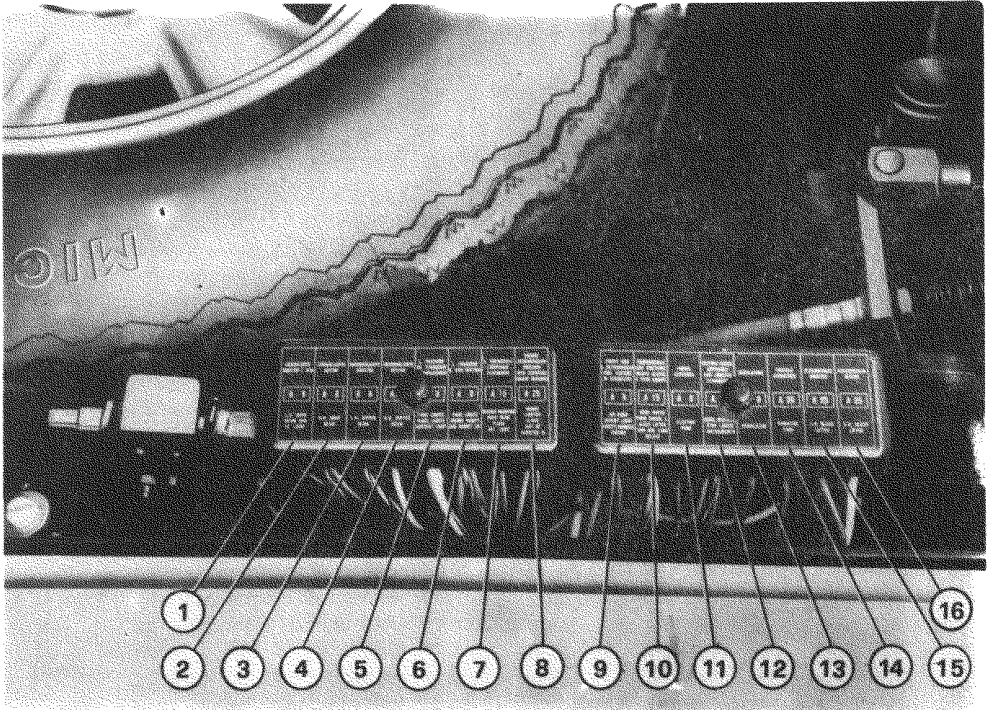

31) -- Fuse boxes (U.S. Safety Standard 108).

- | | |
|--|---|
| <p>1) A8 --L.H. Main beam and w.light.</p> <p>2) A8 --R.H. Main beam.</p> <p>3) A8 --L.H. Dipped beam.</p> <p>4) A8 --R.H. Dipped beam.</p> <p>5) A8 --Parking lights - Instruments lights - Ash tray light.</p> <p>6) A8 --Parking lights - Engine compartment light - Luggage compartment light.</p> <p>7) A15 --Vehicular hazard warning signal - Main beam flash - Interior light.</p> <p>8) A25 --Horns-Cigar lighter-Clock-Remove Key indicator.</p> | <p>9) A25--Heater-Reverse light-Windshield wiper.</p> <p>10) A15--Internal ventilators - Stop lights.</p> <p>11) A8 --Electric fuel pump - Instruments.</p> <p>12) A15--Air pump - Turn signal lights - Safety harnesses circuit - Glass lifter and radiator fans relays.</p> <p>13) A8 --Regulator.</p> <p>14) A25--Radiator fans.</p> <p>15) A25--L.H. Glass lifter.</p> <p>16) A25--R.H. Glass lifter.</p> |
|--|---|

WIRING DIAGRAM LEGEND

- 1—Sealed beams-main and dip beams.
- 2—Front lights-parking and direction indicator lights.
- 3—Fog lights (on request).
- 4—Side markers - front and rear.
- 5—Cooling fan motors.
- 6—Temperature sensitive switch for radiator fans.
- 7—Heater fan motor.
- 8—Horn compressor motor.
- 9—Front compartment light.
- 10—Battery.
- 11—Electrical panel.
- 12—Fuse box (8 Fuses).
- 13—Fuse 15A protecting fog lights.
- 14—Terminal board always live.
- 15—Relay for brake efficiency warning light (SIPEA T 5210).
- 16—Regulator.
- 17—Relay for window winder circuit (Lucas 33213).
- 18—Direction Indicator flasher.
- 19—Radiator cooling fan relay (Lucas 33213).
- 20—Horn relay.
- 21—Main beam,dip beam and side light relay(Lucas33231).
- 22—Fog light switch (on request).
- 23—Windshield washer control.
- 24—Windshield wiper motor.
- 25—Stop light switch.
- 26—Heater fan switch.
- 27—Cigar lighter.
- 28—Instrument light rheostat.
- 29—
- 30—Instrument lights.
- 31—Electronic rev counter.
- 32—Main beam warning light.
- 33—Speedometer.
- 34—Parking light warning
- 35—Direction indicator warning light.
- 36—Wiper and screen washer control lever.
- 37—Direction indicator control lever.
- 38—Parking light and main/dip beam switch.
- 39—Relay switch for parking lights,main and dip beams.
- 40—Horn button.
- 41—Reverse light switch.
- 42—Fuel level sender unit.
- 43—Engine compartment light.
- 44—Alternator.
- 45—Electric fuel pump.
- 46—Starter motor.
- 47—Interior light.
- 48—Oil temperature sender unit.
- 49—Water temperature sender unit.
- 50—Sparking plugs.
- 51—Distributor.
- 52—Vehicular hazard warning light flasher.
- 53—Coil for Ignition(electronic and emergency) (Marelli BAE 203A).
- 54—
- 55—Ignition electronic unit.
- 56—Reverse light.
- 57—Luggage compartment light.
- 58—Rear direction indicator lights.
- 59—Rear position and stop lights.
- 60—Number plate lights.
- 61—Ignition switch with steering lock and remove-key buzzer switch.
- 62—Brake system inefficiency warning light.
- 63—Handbrake warning light.
- 64—Handbrake warning light switch.
- 65—Low oil pressure warning light and sender unit.
- 66—Oil pressure gauge.
- 67—Interior ventilating fan motor.
- 68—Door opening marker light.
- 69—Door opening marker light switch.
- 70—Brake circuit pressure control device.
- 71—Ash tray light.
- 72—Vehicular hazard warning signal switch.
- 73—Electric window winder switch.
- 74—Window winder motor.
- 75—Alternator fuse box (two fuses : 60A and 8A).
- 76—Remove-key Indicator buzzer.
- 77—Remove-key Indicator buzzer jam switch (on door pillar).
- 78—Distributor microswitch.
- 79—Air pump electromagnetic clutch.
- 80—Air pump clutch control unit.
- 81—Relay for control unit 80(Lucas 33232).
- 82—Switch on gearbox:closed only with a gear on.
- 83—Switch on driver's safety belt : open with fastened belt.
- 84—Switch on passenger's seat: closed with passenger seated.
- 85—Switch on passenger's safety belt: open with fastened belt.
- 85/1—Switch on driver's seat:closed with driver seated.
- 86—Unfastened-belt acoustic signal.
- 87—Unfastened-belt warning light.
- 88—Switch panel light.
- 89—Starter motor seat belts relay.
- 90—Anti-hop device for microswitch 78,

- 91—Motor fan for evaporator unit (on request).
- 92—Rheostat to control evaporator fan speed(on request).
- 93—Electromagnetic clutch for air conditioning compressor (on request).
- 93/1-Press switch for engine emergency start.
- 94—Switch controlling motor fan 91 speed(on request).
- 95—Air conditioner cooling unit temperature control knob (on request).
- 96—Relay switch for right radiator fan.
- 97—Min pressure switch for air conditioner(on request).
- 98—Max pressure switch for air conditioner(on request).
- 99—Safety belts and ignition switch electronic unit control.
- 100-Alternator warning light.
- 101-Alternator warning light relay.

Aina

FERRARI SOCIETÀ PER AZIONI ESERCIZIO FABBRICHE AUTOMOBILI E CORSE